

REV.	DATE	ECO	DESCRIPTION	BY	CK	APP
-	9/22/10	N/A	INITIAL RELEASE	RB		N/A

9F61BKW398
DWG# 701533

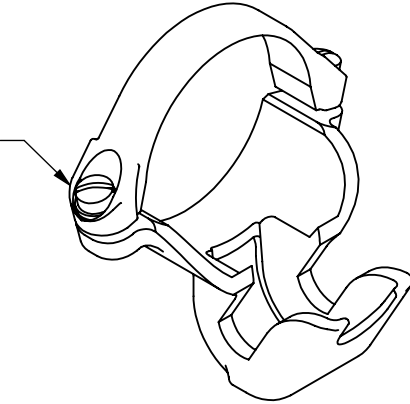

9F61BNW401
DWG# 701518

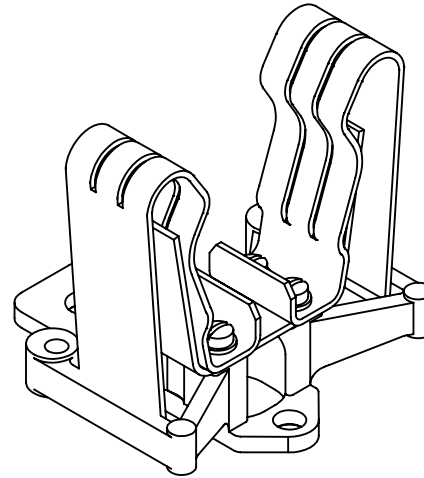

9F61BDW805
DWG# 701560

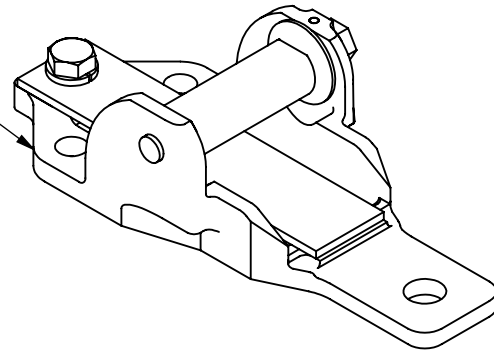

9F61AAW612
DWG# 701544

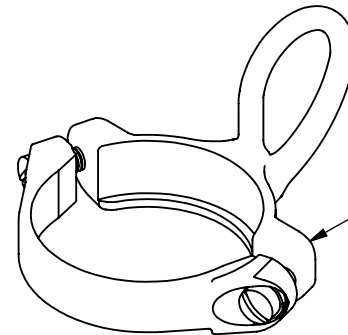

DIMENSIONS IN [] ARE MILLIMETERS



MERSEN USA NEWBURYPORT-MA, LLC
374 MERRIMAC STREET
NEWBURYPORT, MA 01950

9F61BNW732
SP 3 IN. D LIVE PARTS FD

OUTLINE DIMENSIONS
NOT TO BE USED FOR PRODUCTION

PRODUCT MANAGER

SIGN:

DATE:

DESIGN ENGINEER

SIGN:

DATE:

701538

REV.	DATE	ECO	DESCRIPTION	BY	CK	APP
-	8/19/10	N/A	INITIAL RELEASE	RB	NA	N/A

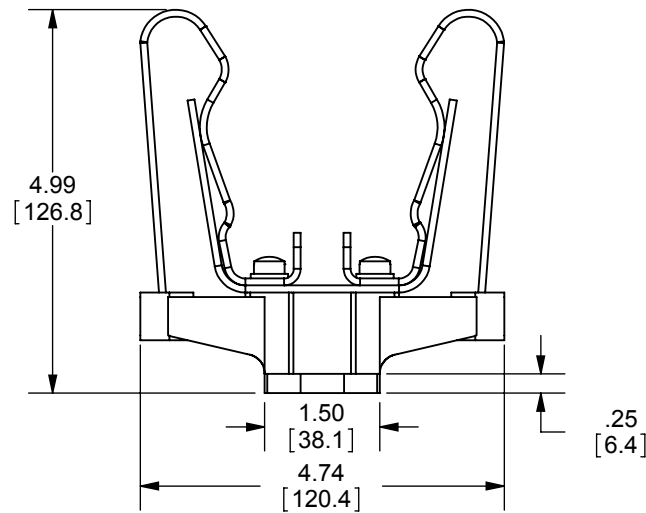
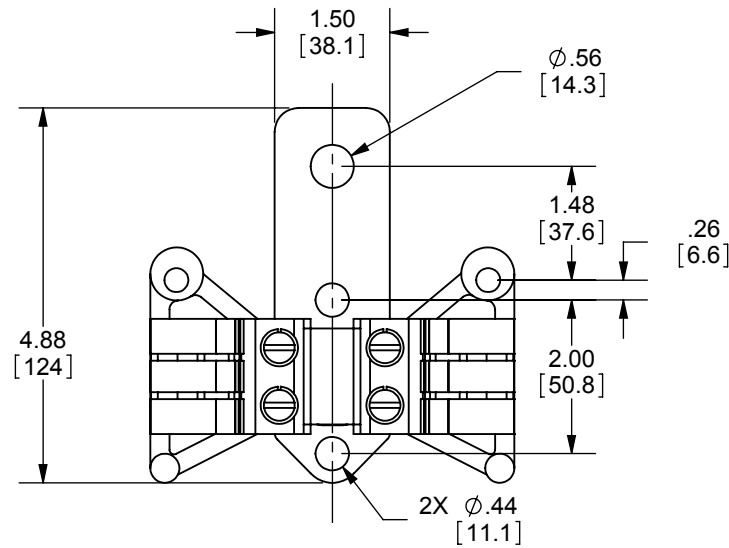

DIMENSIONS IN [] ARE MILLIMETERS



MERSEN USA NEWBURYPORT-MA, LLC
374 MERRIMAC STREET
NEWBURYPORT, MA 01950

9F61BNW401
SP SINGLE 3 IN. D
LIVE PARTS

OUTLINE DIMENSIONS
NOT TO BE USED FOR PRODUCTION

701518

PRODUCT MANAGER

SIGN:

DATE:

DESIGN ENGINEER

SIGN:

DATE:

REV.	DATE	ECO	DESCRIPTION	BY	CK	APP
-	9/20/10	N/A	INITIAL RELEASE	RB		N/A

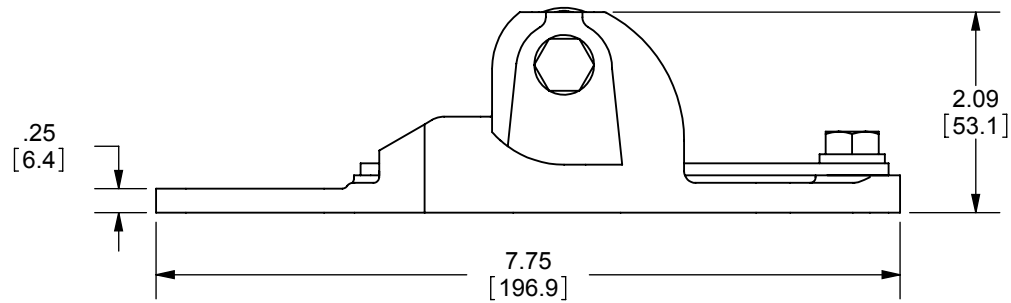
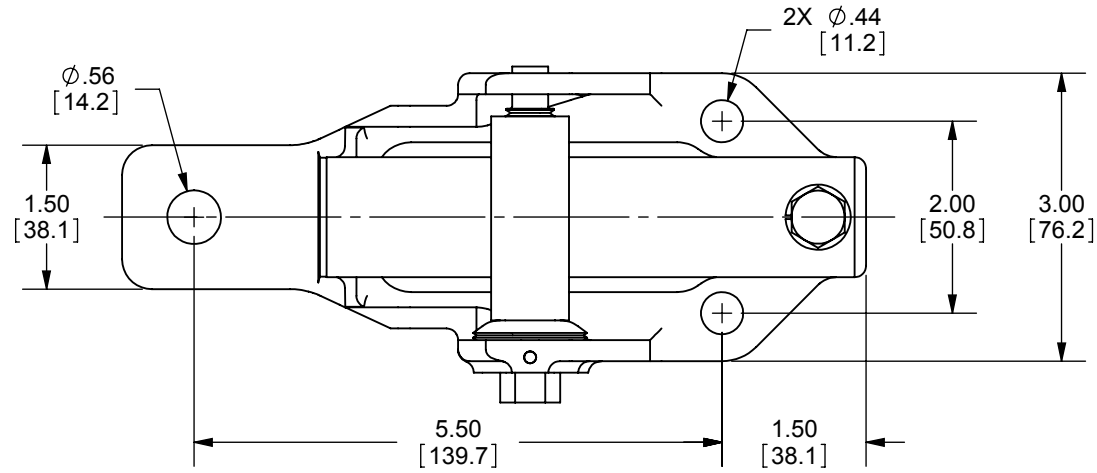

DIMENSIONS IN [] ARE MILLIMETERS



MERSEN USA NEWBURYPORT-MA, LLC
374 MERRIMAC STREET
NEWBURYPORT, MA 01950

9F61BDW805
HINGE SUPPORT
SHORT TAB FD

OUTLINE DIMENSIONS
NOT TO BE USED FOR PRODUCTION

701560

PRODUCT MANAGER

SIGN:

DATE:

DESIGN ENGINEER

SIGN:

DATE:

REV.	DATE	ECO	DESCRIPTION	BY	CK	APP
-	9/21/10	N/A	INITIAL RELEASE	RB	NA	N/A

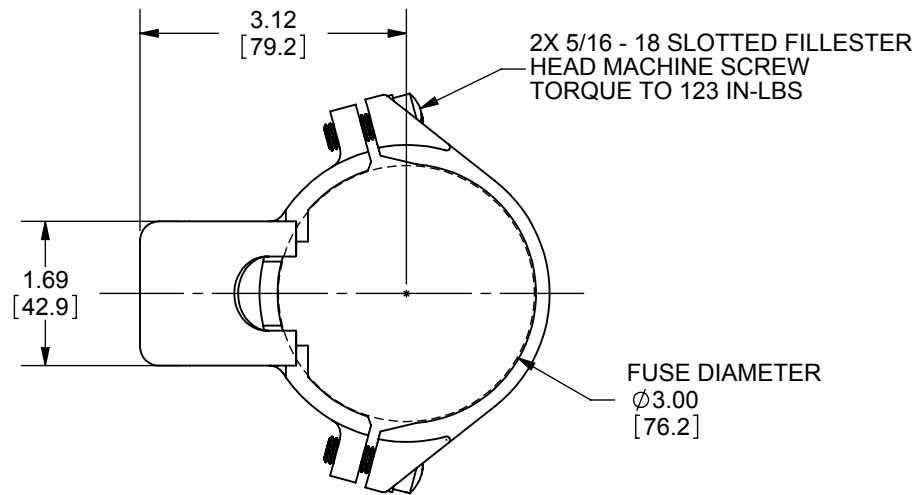
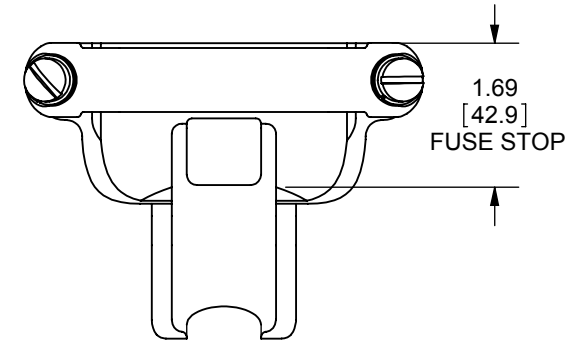
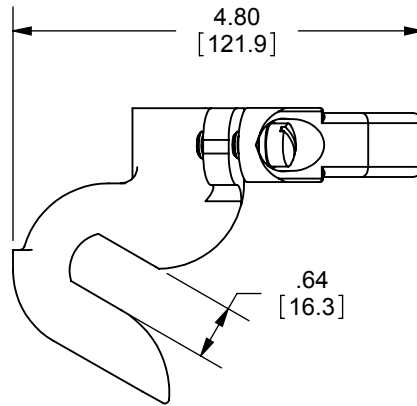
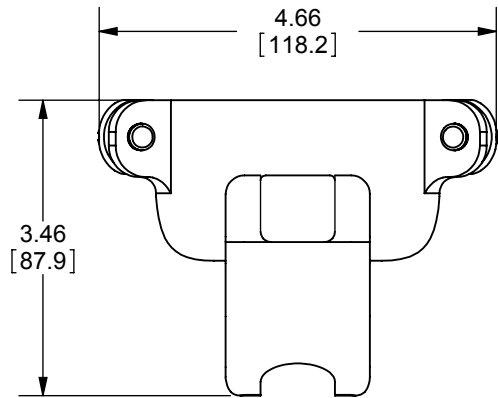

DIMENSIONS IN [] ARE MILLIMETERS



MERSEN USA NEWBURYPORT-MA, LLC
374 MERRIMAC STREET
NEWBURYPORT, MA 01950

9F61BKW398
3 IN. HINGE TRUNION FD

OUTLINE DIMENSIONS
NOT TO BE USED FOR PRODUCTION

701533

PRODUCT MANAGER

SIGN:

DATE:

DESIGN ENGINEER

SIGN:

DATE:

REV.	DATE	ECO	DESCRIPTION	BY	CK	APP
-	9/21/10	N/A	INITIAL RELEASE	RB	NA	N/A

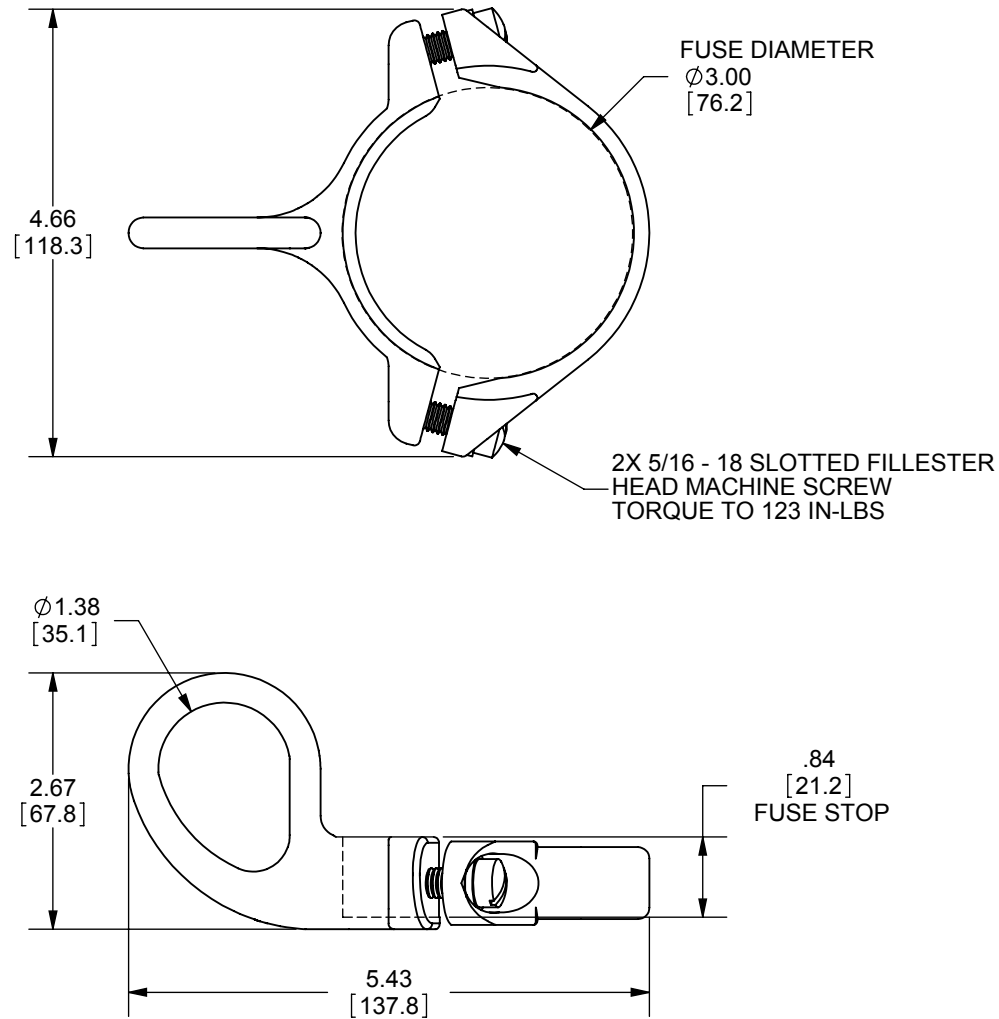

DIMENSIONS IN [] ARE MILLIMETERS



MERSEN USA NEWBURYPORT-MA, LLC
 374 MERRIMAC STREET
 NEWBURYPORT, MA 01950

9F61AWW612
 3 IN. OPERATING EYE FD

OUTLINE DIMENSIONS
 NOT TO BE USED FOR PRODUCTION

701544

PRODUCT MANAGER

DESIGN ENGINEER

SIGN:

SIGN:

DATE:

DATE: