

| REV. | DATE | ECO | DESCRIPTION | BY | CK | APP |
|------|---------|-----|-----------------|----|----|-----|
| - | 8/18/10 | N/A | INITIAL RELEASE | RB | NA | N/A |

4X 1/4 REGULAR HELICAL
SPRING LOCK WASHER

4X 1/4 - 20 SLOTTED FILLESTER
HEAD MACHINE SCREW
TORQUE TO 68.8 IN-LBS

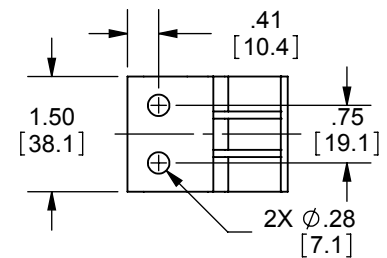
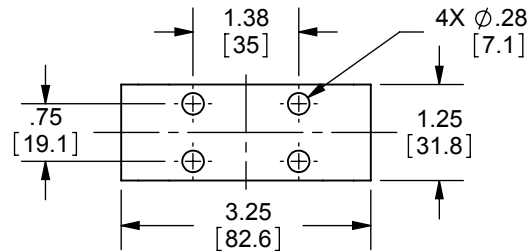
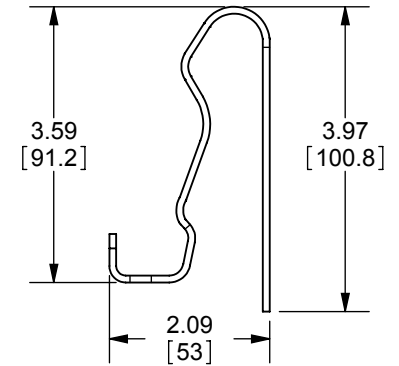
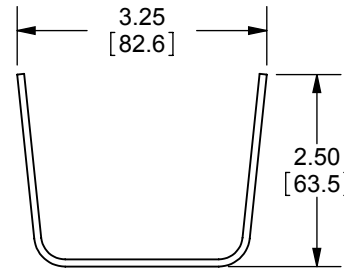
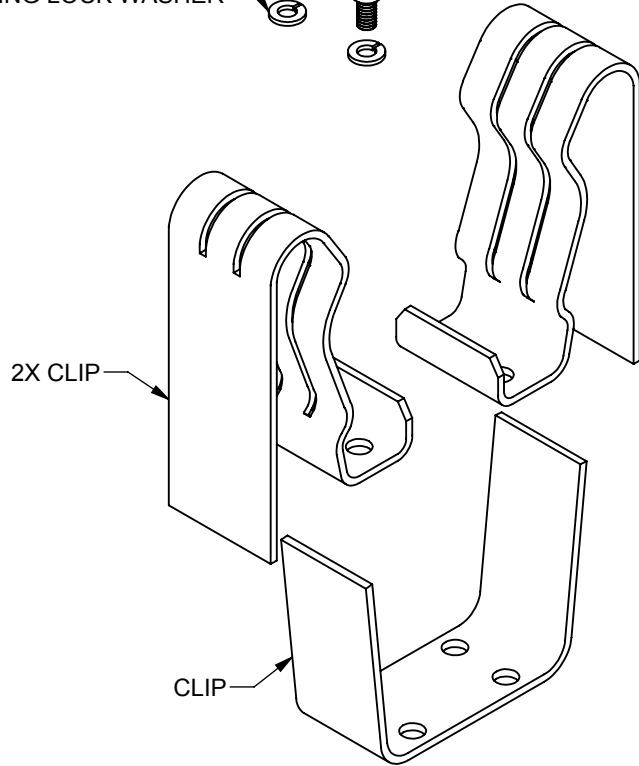

DIMENSIONS IN [] ARE MILLIMETERS



MERSEN USA NEWBURYPORT-MA, LLC
374 MERRIMAC STREET
NEWBURYPORT, MA 01950

9F61BWW459
SP 3 IN. D CLIP

OUTLINE DIMENSIONS
NOT TO BE USED FOR PRODUCTION

701513

PRODUCT MANAGER

DESIGN ENGINEER

SIGN:

SIGN:

DATE:

DATE: