

REV.	DATE	ECO	DESCRIPTION	BY	CK	APP
-	8/23/10	N/A	INITIAL RELEASE	RB	NA	N/A

2X 8 - 36 X .500 ROUND HEAD  
SLOTTED MACHINE SCREW  
TORQUE TO 19.8 IN-LBS

2X #8 REGULAR HELICAL  
SPRING LOCK WASHER

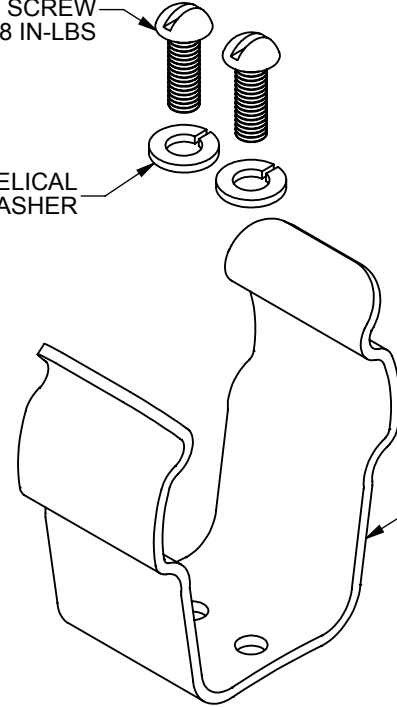

9F61AWW632  
FUSE SUPPORT PARTS  
DWG# 701519

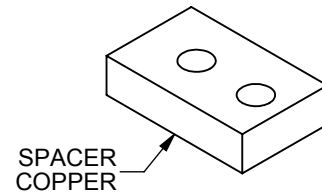

SPACER  
COPPER

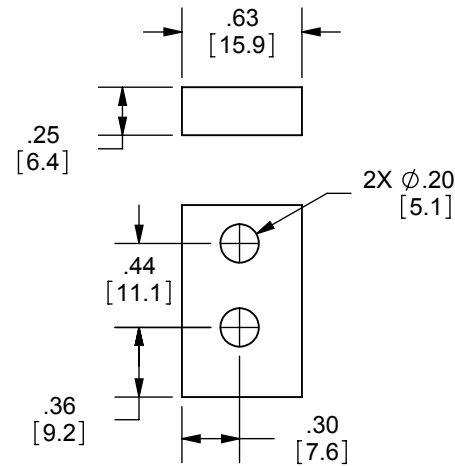

DIMENSIONS IN [ ] ARE MILLIMETERS



MERSEN USA NEWBURYPORT-MA, LLC  
374 MERRIMAC STREET  
NEWBURYPORT, MA 01950

9F61BWW460  
SP PT 1.6 IN. D CLIP

OUTLINE DIMENSIONS  
NOT TO BE USED FOR PRODUCTION

701520

PRODUCT MANAGER

DESIGN ENGINEER

SIGN:

SIGN:

DATE:

DATE:

REV.	DATE	ECO	DESCRIPTION	BY	CK	APP
-	8/20/10	N/A	INITIAL RELEASE	RB	NA	N/A

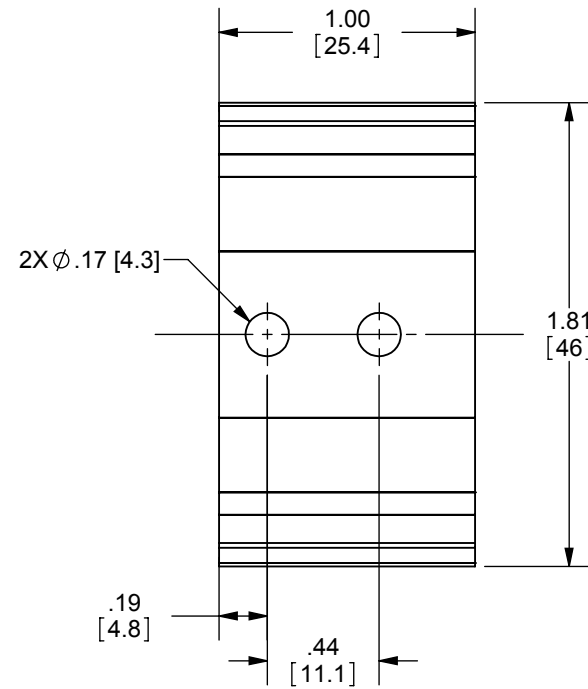
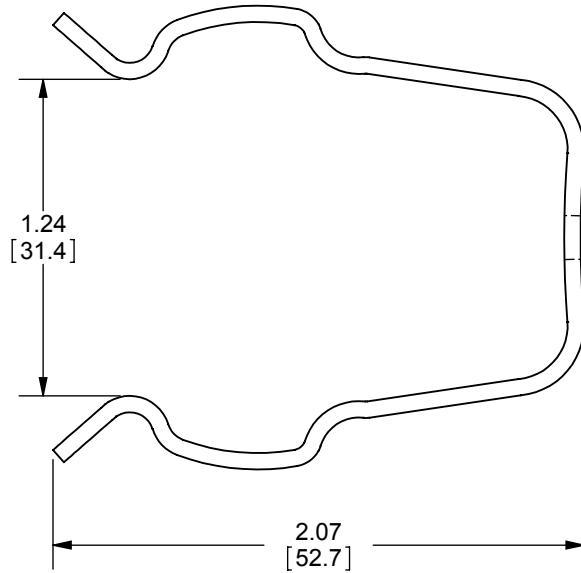

DIMENSIONS IN [ ] ARE MILLIMETERS



MERSEN USA NEWBURYPORT-MA, LLC  
374 MERRIMAC STREET  
NEWBURYPORT, MA 01950

9F61AWW632  
FUSE SUPPORT PARTS

OUTLINE DIMENSIONS  
NOT TO BE USED FOR PRODUCTION

701519

PRODUCT MANAGER

DESIGN ENGINEER

SIGN:

SIGN:

DATE:

DATE: